



Threaded-Body Cylinder
double acting
max. operating pressure 500 bar



Application

Double-acting threaded-body cylinders are used when the return stroke must be effected in a certain time, e.g. with clock-pulse-controlled devices. Of course they can also generate pulling forces.

Description

These double-acting cylinders allow a space saving installation into the fixture body and therefore a hosefree oil supply. The double-wiper protects the piston and enables sealing with very little leakage. Sealing of the cylinders in the fit hole is made by two O-ring/support-ring combinations. Tightening of the cylinder can be made by a pin-type face spanner as per DIN 3116, so the collar can be immersed into the device, if necessary (see page 2).

Material

Piston material: case-hardening steel, hardened.
Housing: free-cutting steel, black oxide.

Important notes

The dimension (depth of bore hole) h has to be strictly observed, as, with regard to the short length we have to dispense with an internal stop.

The insertion chamfer and the bore hole for oil supply have to be rounded in order to secure the seals against damage when screwing in.

The oil supply can be effected at each point outside the fit depth m.

Operating conditions, tolerances and other details see data sheet A 0.100.

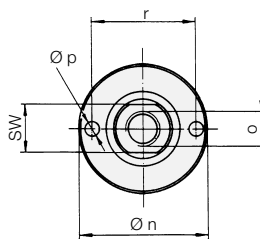
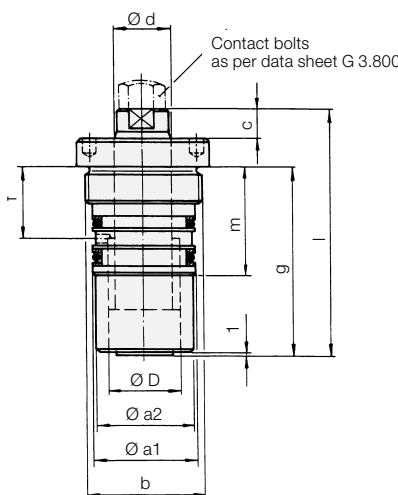

Single connection

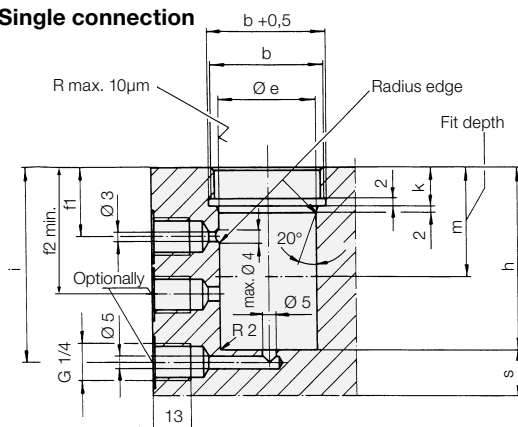

Series connection

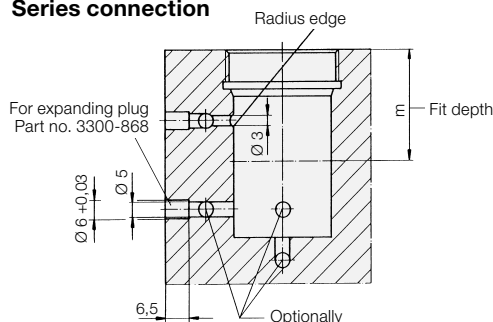

Piston Ø D	[mm]	16	20	25	32	40
Rod Ø d	[mm]	10	12	16	20	25
Hub ± 1	[mm]	16	20	25	32	40
Clamping force a 100 bar	[kN]	2.0	3.1	4.9	8.0	12.6
Clamping force a 500 bar	[kN]	10.0	15.7	24.5	40.2	62.8
Pull thrust a 100 bar	[kN]	1.2	2.0	2.9	4.9	7.7
Pull thrust a 500 bar	[kN]	6.1	10.0	14.5	24.5	38.3
Oil volume / 10 mm stroke	[cm³]	2.0/1.2	3.1/2.0	4.9/2.9	8.0/4.9	12.56/7.7
extension/retraction	[cm³]	2.0/1.2	3.1/2.0	4.9/2.9	8.0/4.9	12.56/7.7
Ø a 1 f7	[mm]	22	28	35	44	55
Ø a 2	[mm]	21	26	33	42	53
b	[mm]	M26 x1.5	M32 x1.5	M40 x1.5	M50 x1.5	M60 x1.5
c	[mm]	6	7	7	10	12
Ø e H7	[mm]	22	28	35	44	55
f1	[mm]	19	20	25	28	30.5
f2 min.	[mm]	34	35	43	48	51
g	[mm]	48	53	65	72	86
h ± 0.2	[mm]	48	53	65	72	86
i	[mm]	53	62	72	79	93
k ± 0.2	[mm]	8.5	10.5	13.5	15.5	17
l ± 1	[mm]	65	67	82	94	112
m + 1	[mm]	30	31	39	44	47
Ø n	[mm]	31	37	44	54	65
o x Gewindetiefe	[mm]	M6 x12	M8 x12	M10 x15	M12 x15	M16 x25
Ø p	[mm]	3.2	4.2	5.2	6.2	6.2
r	[mm]	25	30	35	42	50
s min.*	[mm]	8	10	11	13	16
SW	[mm]	8	10	13	17	22
Seating torque	[Nm]	50	100	200	400	650
Weight	[kg]	0.165	0.25	0.5	0.9	1.7
Temperat. up to 100°C	Part no.	1471001	1472001	1473001	1474001	1475001
Temperat. up to 150°C (FKM)	Part no.	1471011	1472011	1473011	1474011	1475011

* for 500 bar operating pressure and material with 500 N/mm2 breaking strength

Connection possibilities

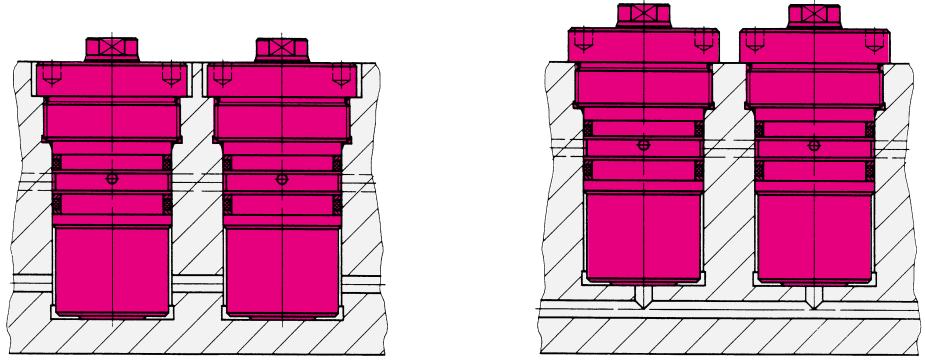

Application example

Double-acting threaded-body cylinders in a multiple clamping bar for a welding fixture (Contact bolt with coupling pin see data sheet G 3.800)

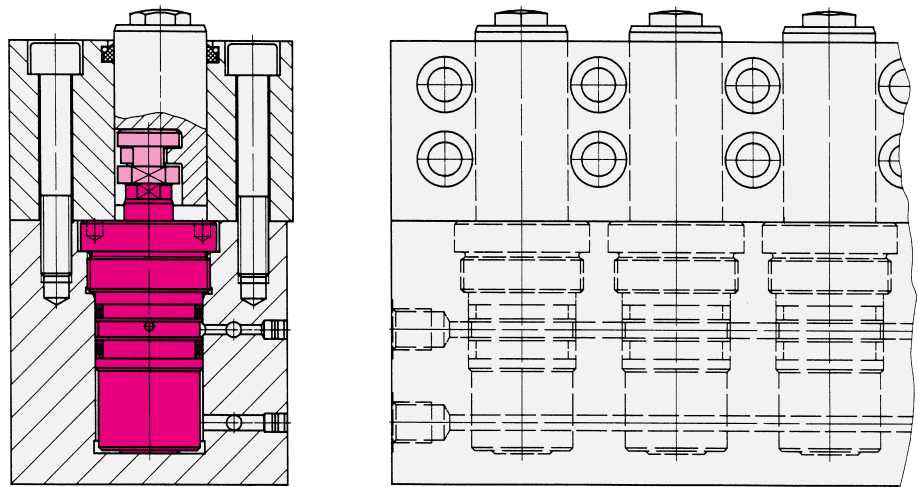

Double-acting threaded-body cylinders as pull-type cylinder for a multiple clamping fixture to mill a wrench flat

